

Centre Number						Candidate Number					
Surname						Other Names					
Notice to Candidate. The work you submit for assessment must be your own. If you copy from someone else or allow another candidate to copy from you, or if you cheat in any other way, you may be disqualified.											
Candidate Declaration. I have read and understood the Notice to Candidate and can confirm that I have produced the attached work without assistance other than that which is acceptable under the scheme of assessment.											
Candidate Signature						Date					

For Examiner's Use	
Examiner's Initials	
Section	Mark
Section A Task 1 Q1	
Section A Task 1 Q2	
Section A Task 2 Q1	
Section B Q1	
Section B Q2	
Section B Q3	
TOTAL	



General Certificate of Education
Advanced Level Examination
June 2014

Physics (Specifications A and B)

PHA6/B6/X

**Unit 6 Investigative and Practical Skills in A2 Physics
Route X Externally Marked Practical Assignment (EMPA)**

Section B Written Test

<p>For this paper you must have:</p> <ul style="list-style-type: none"> • your completed Section A Task 2 question paper / answer booklet. • a ruler • a pencil • a calculator. 	<p>Instructions</p> <ul style="list-style-type: none"> • Use black ink or black ball-point pen. • Fill in the boxes at the top of this page. • Answer all questions. • You must answer the questions in the space provided. Do not write outside the box around each page or on blank pages. • Show all your working. • Do all rough work in this book. Cross through any work you do not want to be marked.
<p>Time allowed</p> <ul style="list-style-type: none"> • 1 hour 15 minutes 	<p>Information</p> <ul style="list-style-type: none"> • The marks for questions are shown in brackets. • The maximum mark for this paper is 25.
<p>Details of additional assistance (if any). Did the candidate receive any help or information in the production of this work? If you answer yes, give the details below or on a separate page.</p> <p>Yes <input type="checkbox"/> No <input type="checkbox"/></p>	

<p>Practical Skills Verification Teacher Declaration: I confirm that the candidate has met the requirement of the practical skills verification (PSV) in accordance with the instructions and criteria in section 3.8 of the specification.</p>	<p>Yes <input type="checkbox"/></p>
--	-------------------------------------

Signature of teacher Date

As part of AQA's commitment to assist students, AQA may make your coursework available on a strictly anonymous basis to teachers, examining staff and students in paper form or electronically, through the Internet or other means, for the purpose of indicating a typical mark or for other educational purposes. In the unlikely event that your coursework is made available for the purposes stated above, you may object to this at any time and we will remove the work on reasonable notice. If you have any concerns please contact AQA.

To see how AQA complies with the Data Protection Act 1988 please see our Privacy Statement at aqa.org.uk.

PHA6/B6/X

Section B

Answer **all** the questions in the spaces provided.

Time allowed 1 hour 15 minutes.

You will need to refer to the work you did in Section A Task 2 when answering these questions.

- 1 (a) (i)** Determine the gradient, G , of your graph (**Figure 6**) of $(\sqrt{l+x} - \sqrt{l})$ against $\frac{1}{T}$.

[2 marks]

.....

$$G = \dots\dots\dots$$

- 1 (a) (ii)** Evaluate $\frac{G}{x}$.

[2 marks]

.....

$$\frac{G}{x} = \dots\dots\dots$$

- 1 (b)** **Figure 7** on page 3 shows a side view and a front view of the apparatus you used in Section A Task 2.

Add suitable annotation to either or both of these views to indicate:

- 1 (b) (i)** where you positioned the fiducial mark in order to measure T
1 (b) (ii) the position from which you viewed the oscillations of the pendulum.

[2 marks]

Figure 7

side view

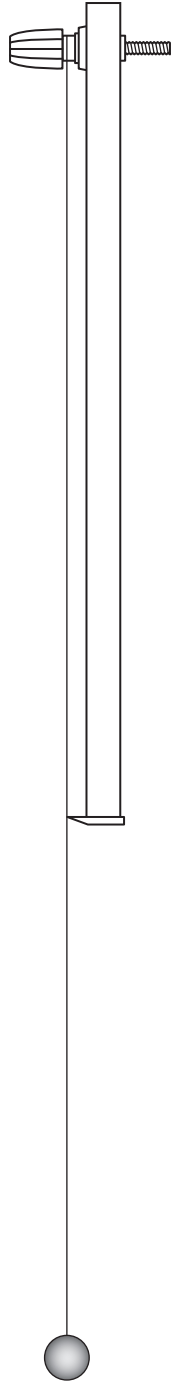

front view

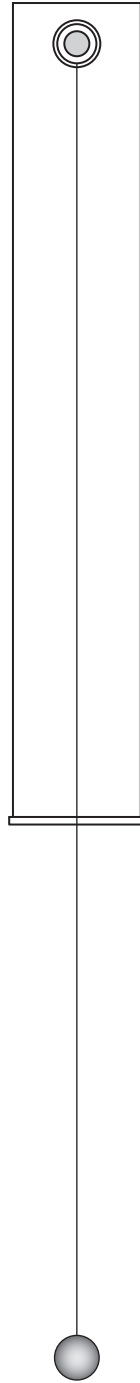

Turn over ►

1 (c) Students A and B make systematic errors when carrying out the experiment.

Student A makes accurate measurements to determine l and T but records a value for x that is too large.

Student B makes accurate measurements to determine l and x but (when measuring T) consistently thinks that 20 oscillations are being counted but the time recorded is for only 19 oscillations.

Explain what effect these systematic errors have:

1 (c) (i) on the graph that student A plots

[2 marks]

.....
.....
.....
.....
.....
.....
.....

1 (c) (ii) on the graph that student B plots.

[2 marks]

.....
.....
.....
.....
.....
.....
.....

1 (c) (iii) The students are told that $(\sqrt{l+x} - \sqrt{l})$ is directly proportional to $\frac{1}{T}$.

Suggest why the systematic error made by student A is easier to discover than that made by student B.

[1 mark]

.....
.....
.....

- 2 By modifying the circuit you used in Question 2 of Section A Task 1 a student designs a capacitance meter. The circuit used by the student is shown in **Figure 8**.

Figure 8

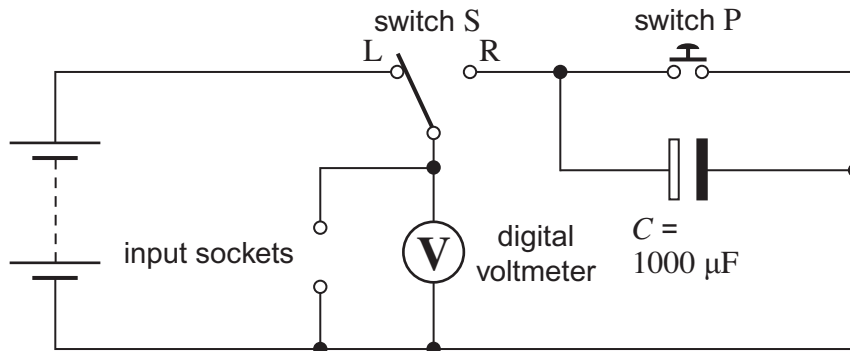

A capacitor of unknown capacitance is connected to the input sockets. Switch S is moved to position L and switch P is briefly pressed, then the voltmeter reading, V_0 , is recorded. When switch S is moved to position R the voltmeter reading falls to a new value, V .

The capacitance of the unknown capacitor, is given by $C_U = \frac{C \times V}{V_0 - V}$ where $C = 1000 \mu\text{F}$ for the circuit in **Figure 8**.

- 2 (a) Suggest why a digital voltmeter (rather than an analogue voltmeter) should be used. **[1 mark]**

.....

.....

- 2 (b) The $1000 \mu\text{F}$ capacitor may differ by up to 20% from its stated value. For a certain unknown capacitance, C_U , V_0 is $6.0 \text{ V} \pm 0.1 \text{ V}$ and V is $2.3 \text{ V} \pm 0.1 \text{ V}$.

Determine the largest possible capacitance, C_U .

[2 marks]

largest possible capacitance, $C_U = \dots\dots\dots$

Turn over ►

- 2 (c) **Figure 9** shows a circuit that can be used to determine the capacitance of an unknown capacitor.

Figure 9

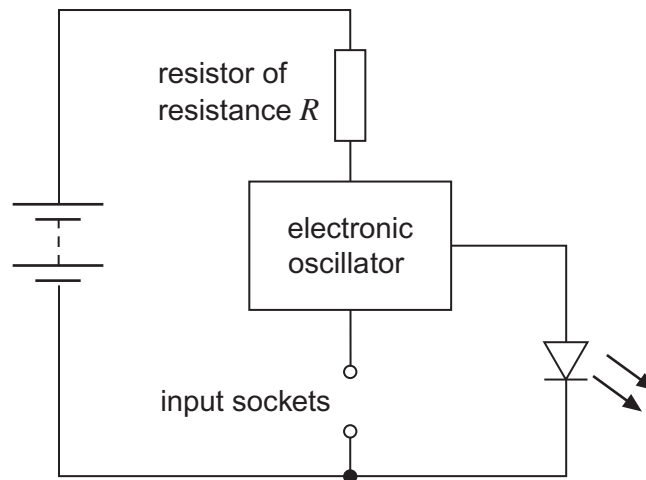

When a capacitor of capacitance C is connected to the input sockets, the LED flashes at a steady frequency, f , which depends on C and R .

If R is known and f is measured, C can be found using the chart in **Figure 11**: instructions on the use of this chart are given at the bottom of page 7.

The student makes three measurements of the time for 5 flashes of the LED when $R = 5.0 \text{ k}\Omega$.

Figure 10

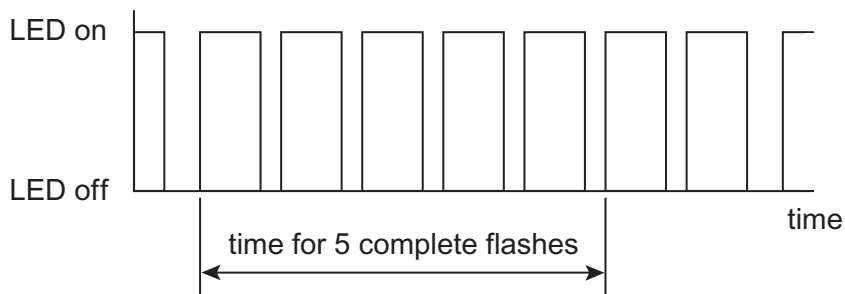

time for 5 flashes of the LED/s		
47.6	46.4	46.7

Use the student's measurements to determine C , showing clearly on **Figure 11** how you arrived at your result.

.....

$C = \dots\dots\dots$

[3 marks]

6

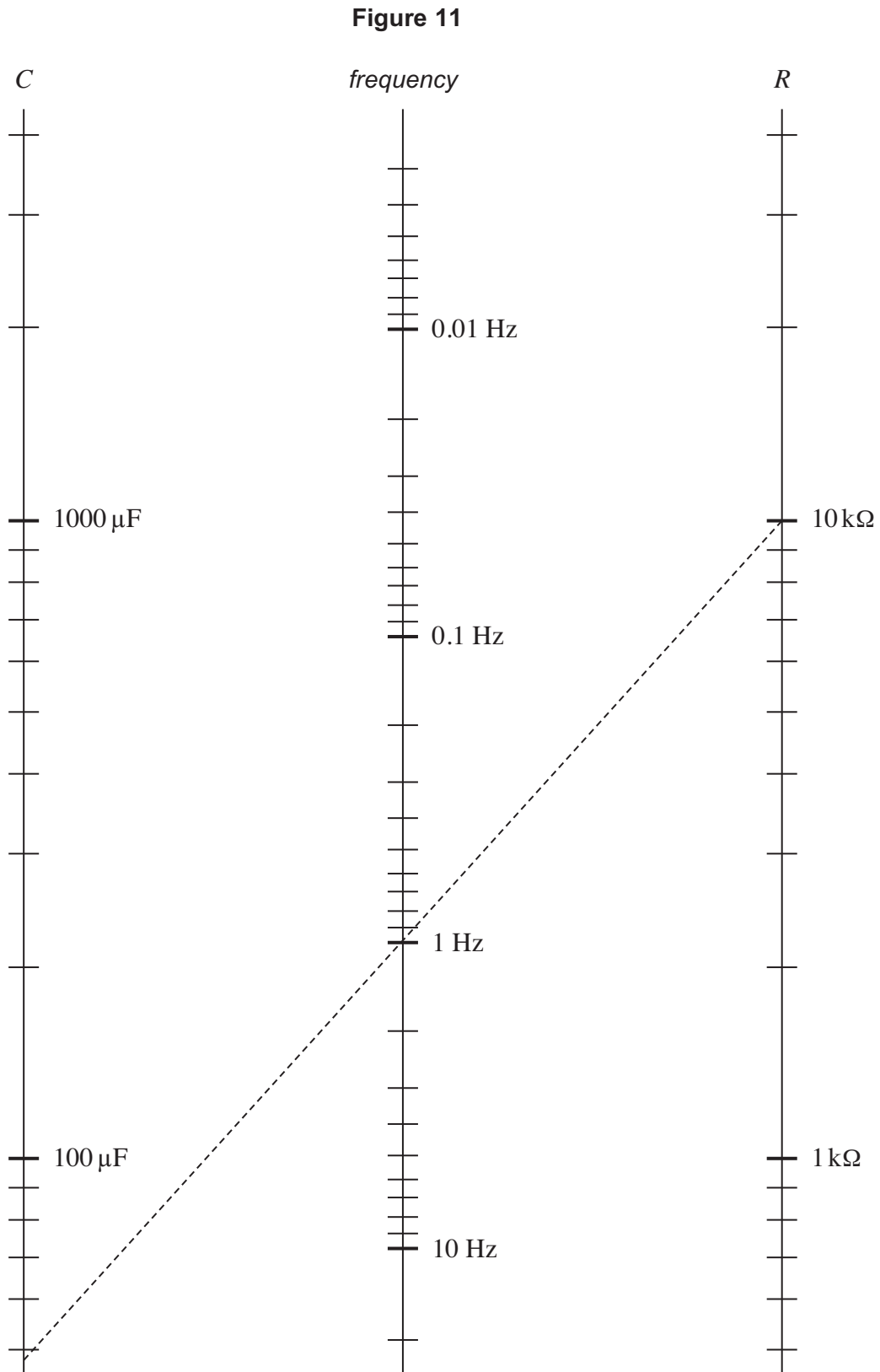

The dotted line joining the three scales in **Figure 11** shows the capacitance that can be found when the values of R and f are known, eg when R is $10\ \text{k}\Omega$ and f is $1.0\ \text{Hz}$, the capacitance is just less than $50\ \mu\text{F}$.

Turn over ►

- 3 An experiment is carried out to determine the specific heat capacity of water using the apparatus shown in **Figure 12**.

Figure 12

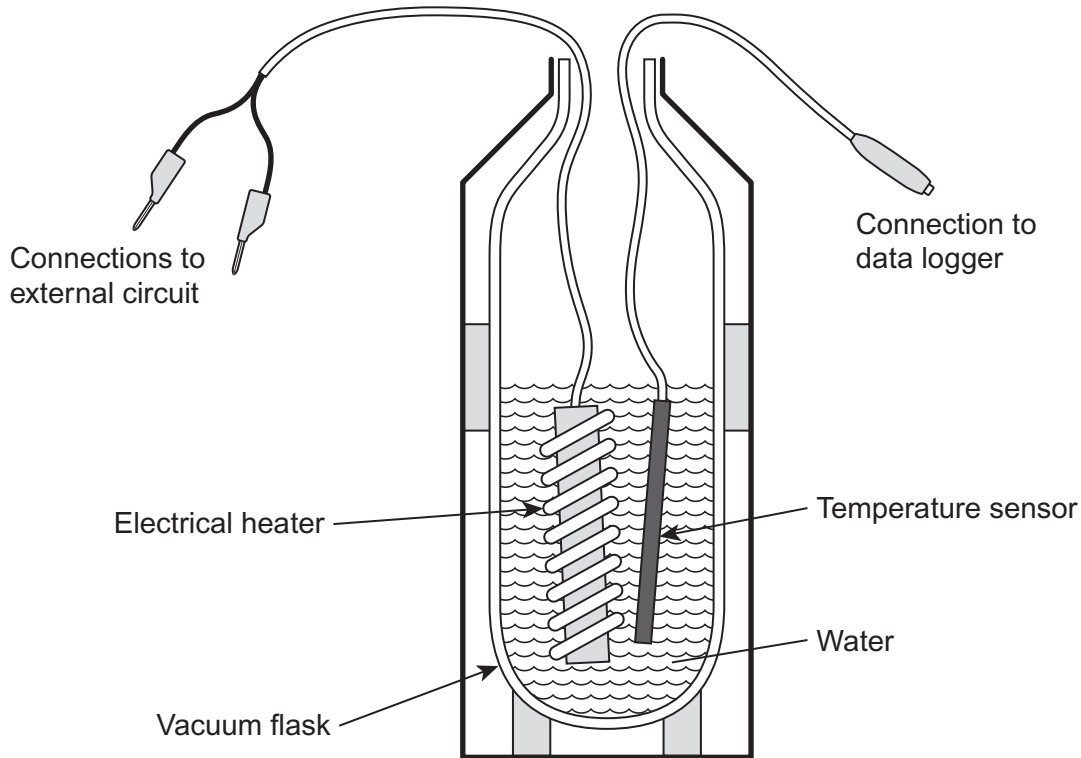

Energy is supplied to the water using an electrical heater.
Heat loss to the surroundings is minimised by placing the water in a vacuum flask.
The temperature of the water is determined using a temperature sensor connected to a data logger.

The procedure is as follows.

- The mass of the water is determined using a balance.
- The heater is connected to a circuit that allows measurements to be made so that the mean power supplied to the heater can be calculated.
- Data logging starts as the heater is switched on.
- The heater is switched off after 500 s.
- Data logging ends after 800 s.

- 3 (a) If the sample rate of the data logger = 0.05 Hz, how many samples are recorded while data are being sent to the data logger?

[1 mark]

.....
.....

number of samples =

3 (b) (i) Complete the diagram in **Figure 13** to show the circuit that should be connected to the heater.

[1 mark]

Figure 13

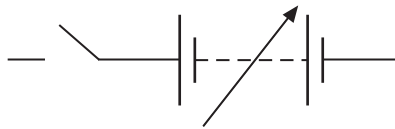
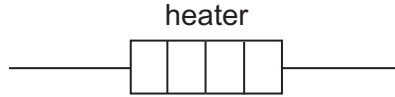

3 (b) (ii) During the experiment it is noticed that the measurements being made to determine power are not steady.
Explain how the mean power transformed in the heater should be determined.

[1 mark]

.....

.....

.....

.....

.....

.....

- 3 (c) The data collected in the experiment are displayed on the graph of temperature, θ , against time, t , shown in **Figure 14**.

Figure 14

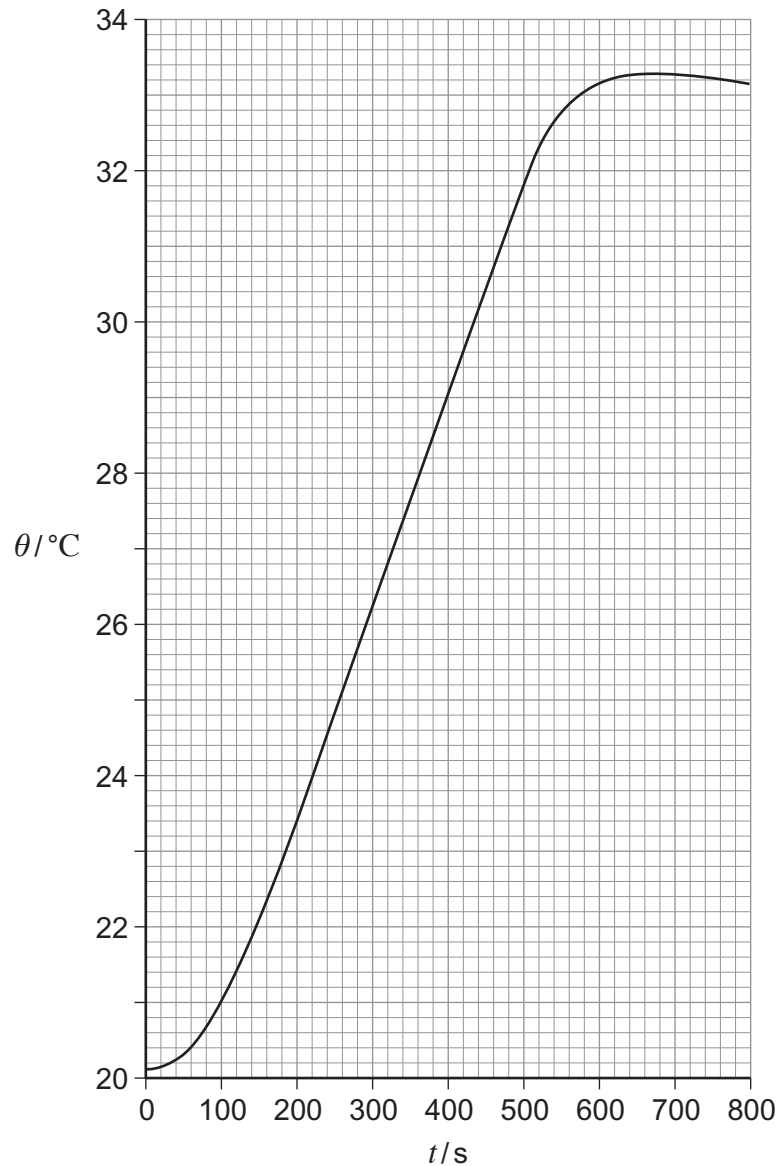

- 3 (c) (i) Why does the temperature indicated by the temperature sensor continue to increase after the heater is switched off at $t = 500\text{s}$?

[1 mark]

.....

.....

.....

3 (c) (ii) In the experiment represented in **Figure 14**

the mass of water in the flask = 119 g
the mean power supplied to the heater = 15.2 W.

Use this information together with **Figure 14** to determine the specific heat capacity of the water.

You may wish to use the equation $Q = mc\Delta\theta$.

Note that the graph in **Figure 14** is linear between $t = 180$ s and $t = 400$ s.

[3 marks]

specific heat capacity = $\text{J kg}^{-1} \text{K}^{-1}$

3 (c) (iii) Comment on any discrepancy between your result for the specific heat capacity of water and the accepted value of $4180 \text{ J kg}^{-1} \text{K}^{-1}$.

[1 mark]

.....

.....

.....

END OF QUESTIONS

There are no questions printed on this page

**DO NOT WRITE ON THIS PAGE
ANSWER IN THE SPACES PROVIDED**